

# ***DigiTRAK***<sup>®</sup> MFCB

**Multi-Function Cable Box**

## **Operator's Manual**

403-3400-00-C2, Mar 2019

© 2010–2019 by Digital Control Incorporated. All rights reserved.

### **Trademarks**

The DCI logo, CableLink<sup>®</sup>, DataLog<sup>®</sup>, DigiTrak<sup>®</sup>, Eclipse<sup>®</sup>, F2<sup>®</sup>, F5<sup>®</sup>, iGPS<sup>®</sup>, MFD<sup>®</sup>, SST<sup>®</sup>, target-in-the-box<sup>®</sup>, Target Steering<sup>®</sup>, and TensiTrak<sup>®</sup> are U.S. registered trademarks and DucTrak<sup>™</sup>, FBC<sup>™</sup>, FBP<sup>™</sup>, F Series<sup>™</sup>, FSD<sup>™</sup>, FasTrak<sup>™</sup>, LWD<sup>™</sup>, SBP<sup>™</sup>, SE<sup>™</sup>, SED<sup>™</sup>, SuperCell<sup>™</sup>, and TeleLock<sup>™</sup> are trademarks of Digital Control Incorporated.

### **Limited Warranty**

All products manufactured and sold by Digital Control Incorporated (DCI) are subject to the terms of a Limited Warranty. A copy of the Limited Warranty is included at the end of this manual; it can also be obtained by contacting DCI Customer Service, 425-251-0559 or 800-288-3610, or at DCI's website, [www.digital-control.com](http://www.digital-control.com).

### **Important Notice**

All statements, technical information, and recommendations related to the products of DCI are based on information believed to be reliable, but the accuracy or completeness thereof is not warranted. Before utilizing any DCI product, the user should determine the suitability of the product for its intended use. All statements herein refer to DCI products as delivered by DCI and do not apply to any user customizations not authorized by DCI nor to any third-party products. Nothing herein shall constitute any warranty by DCI nor will anything herein be deemed to modify the terms of DCI's existing Limited Warranty applicable to all DCI products. The most recent version of this manual is available on DCI's [website](#) under Support.

### **Compliance Statement**

This equipment complies with Part 15 of the Rules of the FCC and with Industry Canada license-exempt RSS standards and with Australia Class License 2000 for LIPD (low interference potential devices). Operation is subject to the following two conditions: (1) this equipment may not cause harmful interference, and (2) this equipment must accept any interference received, including interference that may cause undesired operation. DCI is responsible for FCC compliance in the United States: Digital Control Incorporated, 19625 62nd Ave S, Suite B103, Kent WA 98032; phone 425-251-0559 or 800-288-3610.

Changes or modifications to any DCI equipment not expressly approved and carried out by DCI will void the user's Limited Warranty and the FCC's authorization to operate the equipment.

### **CE Requirements**



DigiTrak receivers are classified as Class 2 radio equipment per the R&TTE Directive and may not be legal to operate or require a user license to operate in some countries. The list of restrictions and the required declarations of conformity are available on DCI's [website](#).

## Contact Us

<b>United States</b> <i>DCI Headquarters</i>	19625 62nd Ave S, Suite B103 Kent, Washington 98032, USA +1.425.251.0559 / 1.800.288.3610 +1.425.251.0702 fax <a href="mailto:dcidigital-control.com">dcidigital-control.com</a>
<b>Australia</b>	2/9 Frinton Street Southport QLD 4215 +61.7.5531.4283 +61.7.5531.2617 fax <a href="mailto:dciaustralia.digital-control.com">dciaustralia.digital-control.com</a>
<b>China</b>	368 Xingle Road Huacao Town Minhang District Shanghai 201107, P.R.C. +86.21.6432.5186 +86.21.6432.5187 fax <a href="mailto:dcichina.digital-control.com">dcichina.digital-control.com</a>
<b>Europe</b>	Brueckenstraße 2 97828 Marktheidenfeld Germany +49.9391.810.6100 +49.9391.810.6109 fax <a href="mailto:dcieurope.digital-control.com">dcieurope.digital-control.com</a>
<b>India</b>	DTJ 1023, 10th Floor DLF Tower A, DA District Center Jasola, New Delhi 110044 +91.11.4507.0444 +91.11.4507.0440 fax <a href="mailto:dcindia.digital-control.com">dcindia.digital-control.com</a>
<b>Russia</b>	Molodogvardeyskaya Street, 4 Building 1, Office 5 Moscow, Russia 121467 +7.499.281.8177 +7.499.281.8166 fax <a href="mailto:dcirusssia.digital-control.com">dcirusssia.digital-control.com</a>

## Dear Customer,

Thank you for choosing a DigiTrak locating system. We are extremely proud of the equipment we have been designing and building in Washington State since 1990. We believe in providing a unique, high-quality product and standing behind it with superior customer service and training.

Please take the time to read this entire manual, especially the section on safety. Also, please fill in the product registration card provided with this equipment and either mail it to DCI headquarters, fax it to us at 253-395-2800, or complete and submit the form online at [www.digital-control.com](http://www.digital-control.com).

Feel free to contact us if you have any problems or questions. Our Customer Service department is available 24 hours a day, 7 days a week. International contact information is available on our website.

As the horizontal directional drilling industry grows, we're keeping our eye on the future to develop equipment that will make your job faster and easier. Visit us online any time to see what we're up to.

We welcome your questions, comments, and ideas.

Digital Control Incorporated  
Kent, Washington  
2019

**See our DigiTrak Training Videos on YouTube at [www.youtube.com/dcikent](http://www.youtube.com/dcikent).**

# Table of Contents

<b>Safety Precautions and Warnings</b> .....	<b>1</b>
General .....	1
Equipment and Battery Disposal .....	2
Pre-Drilling Testing .....	2
Interference .....	2
Caring for Your Cable Box .....	3
Caring for Your Transmitter .....	3
<b>Introduction</b> .....	<b>4</b>
<b>MFCB Connections</b> .....	<b>5</b>
<b>Powering the MFCB</b> .....	<b>6</b>
<b>Connecting to the Remote Display</b> .....	<b>7</b>
<b>Connecting to the Cable Transmitter</b> .....	<b>8</b>
<b>Installing Transmitter in Housing</b> .....	<b>9</b>
<b>Cable Mode</b> .....	<b>10</b>
Cable Mode Display Screen .....	10
Roll Offset.....	11
Target Steering .....	12
<b>Appendix A: System Specifications</b> .....	<b>13</b>
Power Requirements .....	13
Environmental Requirements .....	13
<b>Appendix B: Transmitter Wire Repair or Replacement</b> .....	<b>14</b>
<b>Limited Warranty</b>	



# Safety Precautions and Warnings

Carefully review this manual and be sure you always operate your DigiTrak locating system properly to obtain accurate depth, pitch, roll, and locate points. If you have any questions about the operation of the system, please contact DCI Customer Service for assistance.

## General



All operators must read and understand the following safety precautions and warnings and must review this operator's manual before using a DigiTrak Locating System.



Serious injury and death can result if underground drilling equipment makes contact with an underground utility such as a high-voltage electrical cable or a natural gas line.



Substantial property damage and liability can result if underground drilling equipment makes contact with an underground utility such as a telephone, cable TV, fiber-optic, water, or sewer line.



Work slowdowns and cost overruns can occur if drilling operators do not use the drilling or locating equipment correctly to obtain proper performance.



DCI equipment is not explosion-proof and should never be used near flammable or explosive substances.



In the event of electrostatic shock, the display screen may go blank. No data loss will occur. Click the trigger to reset the receiver, or toggle down to reset the remote display.



Hot surfaces can occur on cable transmitters if housing requirements are not met. Always ensure the transmitter is installed properly in the housing during use.

Directional drilling operators **MUST** at all times:

- Understand the safe and proper operation of drilling and locating equipment, including the use of ground mats and proper grounding procedures.
- Ensure that all underground utilities have been located, exposed, and accurately marked prior to drilling.
- Wear protective safety clothing such as dielectric boots, gloves, hard hats, high-visibility vests, and safety glasses.
- Locate and track the transmitter in the drill head accurately and correctly during drilling.
- Maintain a minimum distance of 8 in. (20 cm) from the front of the receiver to the user's torso to ensure compliance with FCC requirements.
- Comply with federal, state, and local governmental regulations (such as OSHA).
- Follow all other safety procedures.

DigiTrak locating systems cannot be used to locate utilities.

Continued exposure of the transmitter to heat due to frictional heating of the drill head can cause inaccurate information to be displayed and may permanently damage the transmitter.

Remove the batteries from all system components during shipping and prolonged storage; damage caused by leakage may occur.

## Equipment and Battery Disposal



This symbol on equipment indicates that the equipment must not be disposed of with your other household waste. Instead, it is your responsibility to dispose of such equipment at a designated collection point for the recycling of batteries or electrical and electronic equipment. If the equipment contains a banned substance, the label will show the pollutant (Cd = Cadmium; Hg = Mercury; Pb = Lead) near this symbol. Before recycling, ensure batteries are discharged or the terminals are covered with adhesive tape to prevent shorting. The separate collection and recycling of your waste equipment at the time of disposal will help conserve natural resources and ensure it is recycled in a manner that protects human health and the environment. For more information about where you can drop off your waste equipment for recycling, please contact your local city office, your household waste disposal service, or the shop where you purchased the equipment.

The battery charger provided with your DigiTrak locating system is designed with adequate safeguards to protect you from shock and other hazards when used as specified within this document. If you use the battery charger in a manner not specified by this document, the protection provided may be impaired. Do not attempt to disassemble the battery charger, it contains no user-serviceable parts. The battery charger shall not be installed into caravans, recreational vehicles, or similar vehicles.

## Pre-Drilling Testing

Before each drilling run, test your DigiTrak locating system with the transmitter inside the drill head to confirm it is operating properly and providing accurate drill head location and heading information.

During drilling, the depth will not be accurate unless:

- The receiver has been properly calibrated and the calibration has been checked for accuracy so the receiver shows the correct depth.
- The transmitter has been located correctly and accurately and the receiver is directly above the transmitter in the drill head underground or at the front locate point.
- The receiver is placed on the ground or held at the correct height-above-ground distance, which has been set correctly.

Always test calibration after you have stopped drilling for any length of time.

## Interference

Interference can cause inaccuracies in the measurement of depth and loss of the transmitter's pitch, roll, or heading. Always perform a background noise check prior to drilling.

- Sources of interference include, but are not limited to, traffic signal loops, invisible dog fences, cable TV, power lines, fiber-trace lines, metal structures, cathodic protection, telephone lines, cell phones, transmission towers, conductive earth, salt, salt water, rebar, and radio frequencies.
- Interference at the remote display may also occur from other sources operating nearby on the same frequency, such as car rental agencies using their remote check-in modules or other directional drilling locating equipment.



- Background noise must be minimal and signal strength must be at least 150 points above the background noise during all locating operations.
- Because this equipment may generate, use, and radiate radio frequency energy, there is no guarantee that interference will not occur at a particular location. If this equipment does interfere with radio or television reception, which can be determined by powering the equipment off and on, try to correct the interference using one or more of the following measures:
  - Reorient or relocate the receiving antenna.
  - Increase the separation between the receiver and affected equipment.
  - Consult the dealer, DCI, or an experienced radio/TV technician for help.
  - Connect the DCI equipment to an outlet on a different circuit.

## Caring for Your Cable Box

Do not disassemble. The cable box contains no user-serviceable parts.

Clean exterior with a damp cloth.

Do not submerge.

Do not pressure-wash.

Ensure all ports remain clean and clear of debris by keeping protective caps on power ports and power post when not in use. Use compressed air or a soft brush to remove debris from the power ports. Use a wire brush to clean the power post.

Send in the Product Registration Card for the 1-year limited warranty.

## Caring for Your Transmitter

If the cable wire becomes exposed at the base of the transmitter, the cable should be trimmed and reinstalled or replaced. Parts for repairing or replacing the cable are provided in the repair kit included with the system. See [Appendix B: Transmitter Wire Repair or Replacement](#) on page 14.

Keep the SST transmitter at least 5 ft. (1.5 m) away from all magnets, including the remote display and cable box, which have magnetic mounts that will damage the transmitter. A protective magnetic shield is provided with the SST transmitter and also available through any authorized DigiTrak dealer. Place the magnetic shield on the end of the SST transmitter whenever the transmitter is not in use.

Send in the Product Registration Card for the 90-day limited warranty.

## Introduction

---

The DigiTrak Multi-Function Cable Box (MFCB), often referred to as just the cable box, is an interface used with a variety of DigiTrak cable transmitters. It provides power to the cable transmitter and sends power and transmitter data to the remote display.

The cable box can be used with the following DigiTrak cable transmitters:

- Eclipse cable transmitter (ECP)
- F Series cable transmitter (FC)
- Eclipse steering tool transmitter (SST)

The cable box can be used with the following DigiTrak remote displays:

- Free-standing Multifunction Display (MFDF)
- Multi-Function Display (MFD), panel-mounted and freestanding
- F Series Display (FSD)

This manual does not give instructions on how to operate your locating system. Please read the operator's manual for your locating system before you use the cable box with your remote display.

Items such as compression fittings, 10-gauge copper wire, heat shrink, butt splices, and collector ring or mud swivel assemblies are not available from DCI. Drill manufacturers or tooling manufacturers will have information on collector ring (slip-ring) assemblies, mud swivels, and compression fittings. Electrical supply houses will carry the rest of the equipment needed to connect the wires as drill rods are added to the drill string.

DCI offers an optional product called the CableLink connection system, which eliminates the need for butt splices and heat shrinks. The CableLink system is permanently installed into the drill pipe, and the wire connection occurs automatically when the pipe ends are threaded together.

The SST system has very specific requirements for the transmitter housing and includes a laptop computer that is integral to the system. Although some information regarding the SST is provided here, please refer to the operator's manual provided with your SST system for complete setup and operation information.

All manuals are available at our website, [www.digitrak.com](http://www.digitrak.com).

For full system compatibility, updates to the software in your cable box and/or remote display may be required.

For more information on obtaining operator's manuals, CableLink, or software upgrades, visit our website, or contact DCI Customer Service.

## MFCB Connections

One side of the cable box has two power ports. Although labeled “Power” and “Remote Display”, they are identical and can be used interchangeably. The other side of the cable box has a power post for connecting the transmitter wire; the serial port is only used with the SST (steering tool) system.

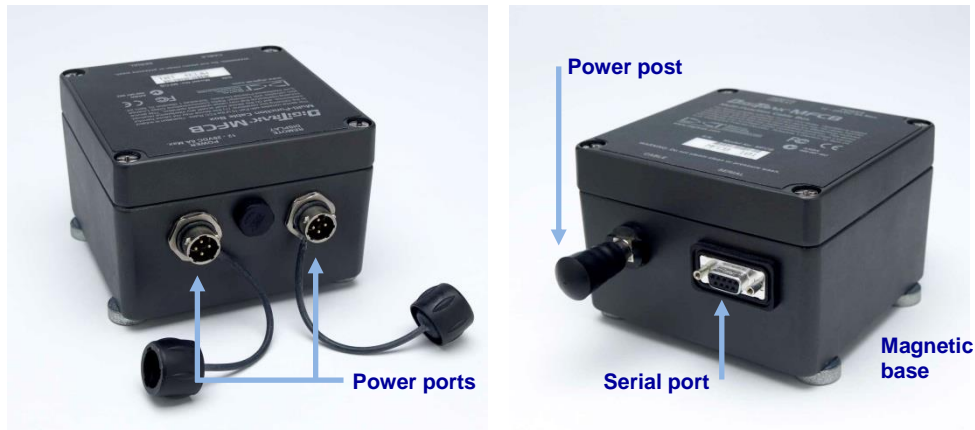

**Multi-Function Cable Box (MFCB)**

Although the DC power cable used to power a freestanding multi-function display through the power port on the drill rig can power the cable box, DCI recommends connecting the cable box directly to an *independent* automotive battery or DC power source *other than* that on the drill rig to avoid voltage disruptions and current draw variations that may interrupt power to the transmitter.

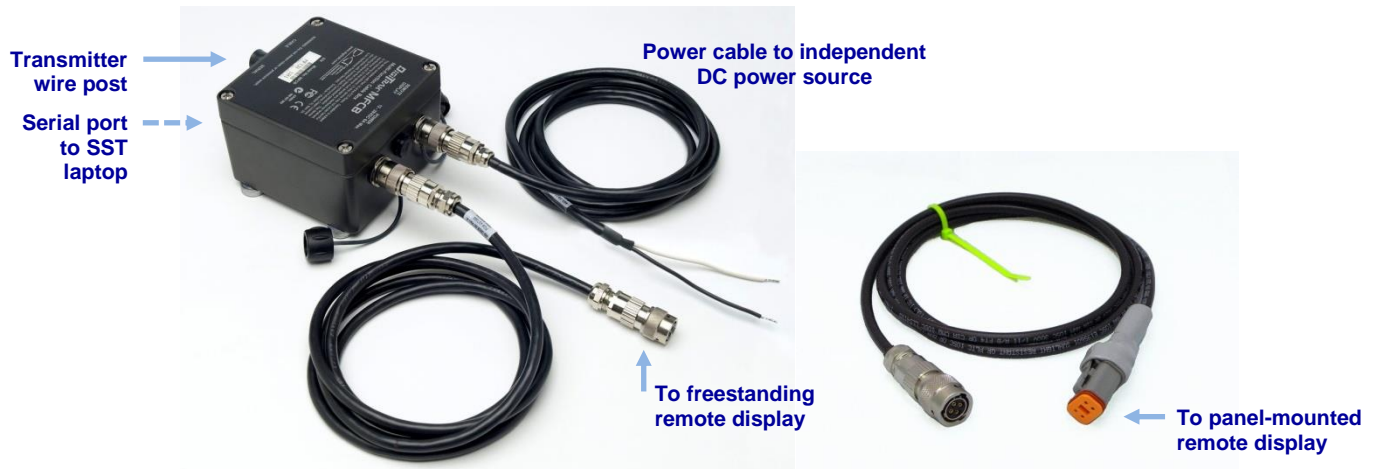

**MFCB Connections**

For a *freestanding* remote display, use the power cable with the same round four-hole connector at both ends (shown in the preceding images at left). For a *panel-mounted* remote display, use the cable with the rectangular orange four-hole connector shown at right. Both cables are included with the MFCB.

## Powering the MFCB

The power ports on the cable box and freestanding remote display (FSD) are keyed for proper alignment. To connect the power cable to the cable box, align the key marks in the connector with the key slots in the power port, then push in and rotate the cable connector clockwise until it locks into place with a snapping sound.

Connect the other end of the power cable to the DC power source. When using the cable with the bare wires at one end (recommended), connect the white wire to the positive terminal and the black wire to the negative terminal. Otherwise, plug the DC cable connector directly into the drill rig's DC power port.

For the best results, power the cable box directly from a standard 12-28 VDC battery or power source, not the drill rig's battery. For bores shorter than 1000 ft (305 m), one 12-volt battery will suffice. If the bore length exceeds 1000 ft, use an additional battery in series as shown in the following diagram.

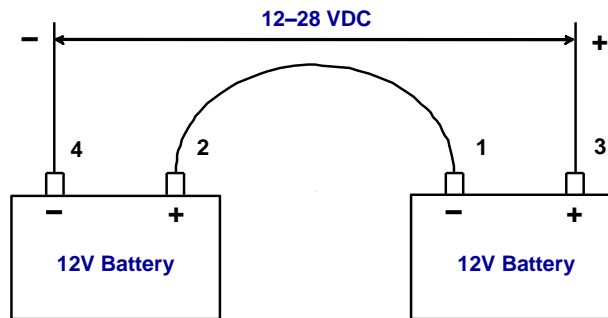

Connect batteries in the order shown: 1,2,3,4.

Disconnect batteries in the opposite order.

**Wiring Batteries In Series**

The following diagram shows how the cable system components are connected when wired directly to a battery. A ground wire must be installed between the negative terminal of a free standing battery and a ground point on the drill rig. The ground point can be the negative terminal on the drill rig's battery or a metal contact point on the drill rig or drill stem.

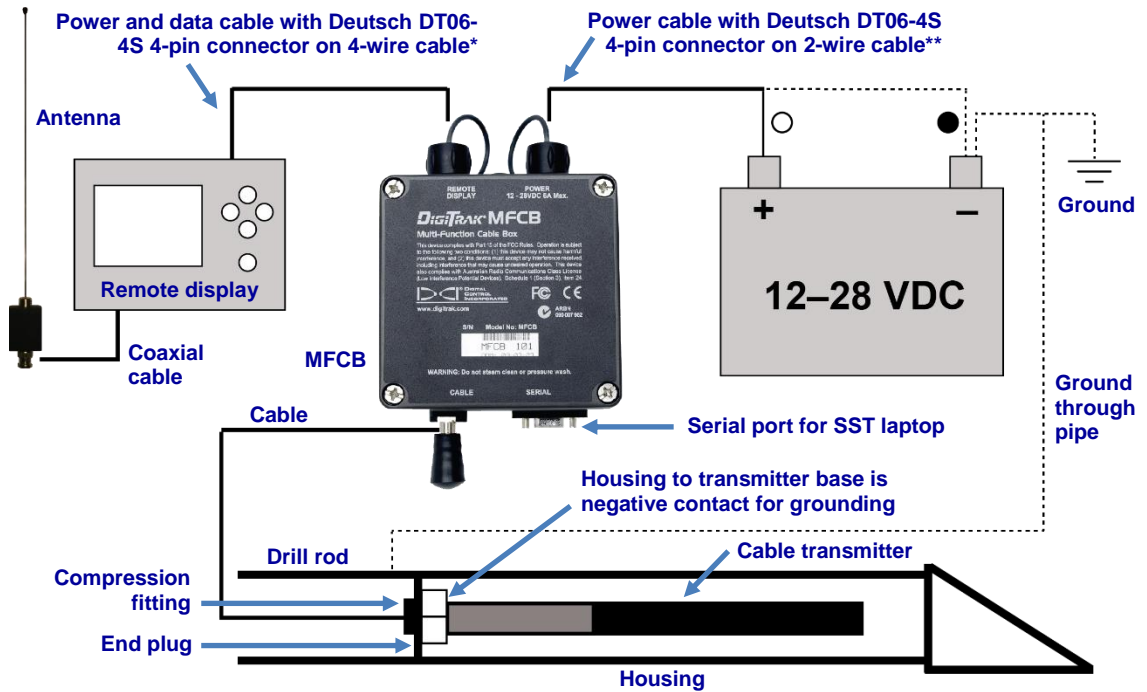

**MFCB Wiring Connections**

\* This cable, part number 460-0002-00, is supplied with the MFCB.

\*\* This cable is available as part number 460-3825-00.

The compression fitting shown in the preceding diagram is a non-DCI part required to seal the transmitter from the drilling fluid. Contact a drill or tooling manufacturer for information on compression fittings.

## Connecting to the Remote Display

For a *freestanding* remote display, use the cable with identical four-hole round connectors at both ends. Align the key marks in the connector with the key slots in one of the power ports, then push in and rotate the connector clockwise until it locks into place with a snapping sound.

For a *panel-mounted* remote display, remove the display from the console and unplug and remove the power cord from the drill rig's power port. Plug the rectangular orange four-hole connector of the new power and data cable (shown on page 5) into the remote display's power port and install the other end into one of the cable box's power ports. Your drill rig dealer can provide additional assistance if needed.

## Connecting to the Cable Transmitter

The cable transmitter must be grounded before it is connected to the cable box. Without a proper ground, no signal or data will be sent to the remote display. The ground point on the cable transmitter is the metal end section of the tube where the wire exits.



**FC Cable Transmitter**

When the cable transmitter is properly fitted into a housing, the ground connection occurs automatically because the housing is grounded through the drill. When testing the cable transmitter outside of a housing, use a piece of wire to ground the transmitter to the negative terminal of the battery.

Once the cable transmitter is properly grounded in a housing, connect it to the cable box by loosening the knob on the power post, inserting the stripped wire end in the hole in the post, and gently retightening the knob.



**Connecting Transmitter Cable to Cable Box**

## Installing Transmitter in Housing

Cable transmitters require special rear-load drill housings. To prevent overheating and for optimum performance, it is critical for the transmitter to be installed correctly. An extraction/insertion tool is provided with the cable transmitter for proper installation and removal.

It is also critical for the slots in the drill housing to meet minimum length, width, and positioning requirements. DCI's transmitters work best in housings with slots that are equally spaced around the circumference of the housing for optimal signal emission. Each slot must be at least  $\frac{1}{16}$  in. (1.6 mm) wide. For accuracy, slot measurements must be taken from the inside of the housing.

For the FC and ECP cable transmitters (19 in./48.26 cm long), the slots must be at least 9 in. (22.9 cm) long and begin at least 2.5 in. (6.4 cm) from the front end of the transmitter:

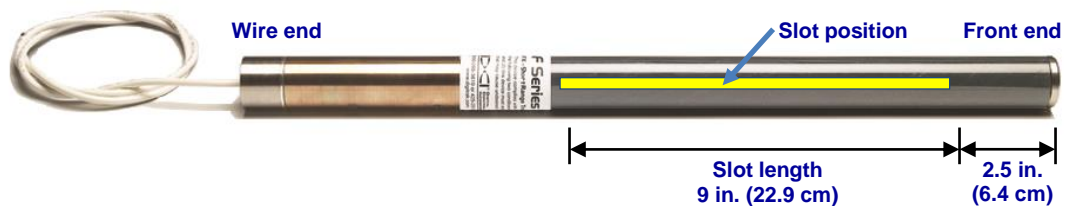

### FC/ECP Transmitter Housing Slot Requirements

The SST cable transmitter (24 in./60.96 cm long) requires a non-magnetic housing. The slots in the housing must be at least 9 in. (22.9 cm) long and begin at least 8.5 in. (21.6 cm) from the front end of the transmitter:

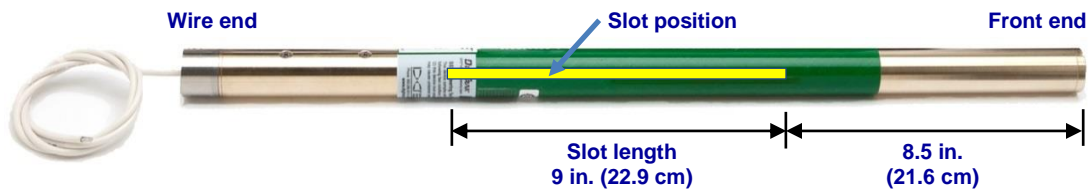

### SST Transmitter Housing Slot Requirements

To install an ECP or FC transmitter into its housing, screw the threaded end of the extraction/insertion tool into one of the two threaded holes ( $\frac{1}{4}$ "-20 thread) in the wire end of the cable transmitter. Gently push the front end of the transmitter into the housing using the extraction/insertion tool until you feel the index slot engage onto the housing key. When the transmitter is properly keyed it will not rotate.



**Warning** Always use the extraction/insertion tool to install or remove the cable transmitter. Never use the transmitter cable for pushing or pulling the transmitter into or from the housing. See [Appendix B](#) on page 14 for information on repair or replacement of the cable.

If after installation the transmitter's 12 o'clock position does not match that of the drill head, set the [Roll Offset](#) as described on page 11.

## Cable Mode

Before using the Multi-Function Cable Box, set both your walkover receiver and remote display to work with a cable transmitter.

For your walkover receiver, reference your operator's manual.

For the remote display, select Cable Mode from the main menu. The cable system components must be properly connected with power supplied before this menu option is available. If you cannot access the cable mode option, you may need a software upgrade; please contact DCI Customer Service.

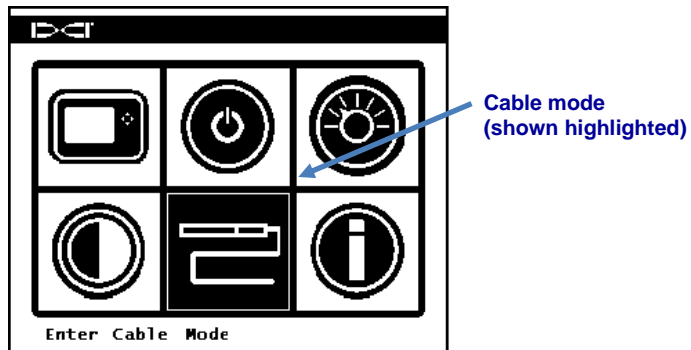

Remote Display Main Menu with Cable Mode Highlighted

## Cable Mode Display Screen

A cable transmitter is identified on the cable mode screen along with the receiver type. The Eclipse and F Series remote displays have almost identical screens. One notable difference is that the Eclipse display will show roll in ½-clock positions, whereas the F Series displays show whole clock positions. The number of clock positions displayed is a function of the transmitter.

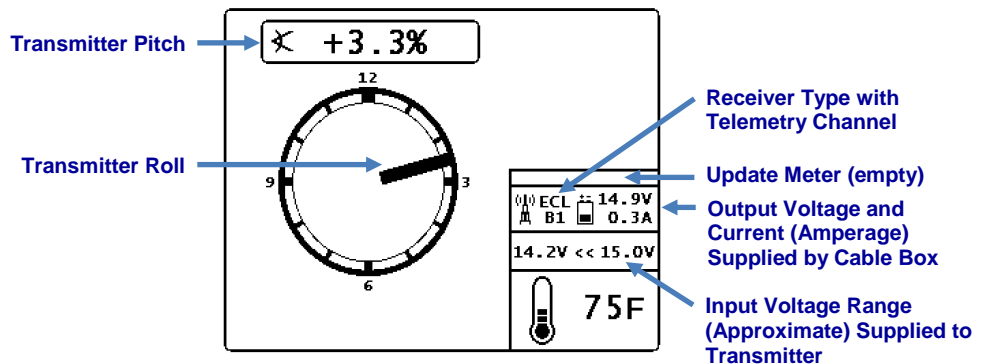

Eclipse Cable Mode Display



The preceding screen shows an empty update meter, which means the remote display is not receiving telemetry data. The roll, pitch, and temperature are provided through the cable. Depth information will display only when the remote is receiving telemetry data, as indicated by bars in the update meter, and the receiver is used to take a depth reading.

## Roll Offset

Use roll offset to match the transmitter's 12 o'clock position with that of the drill head. If roll offset is required, it must be set on both the receiver (see your operator's manual) and the remote display.

To access roll offset on the remote display, push the right direction button while in the Cable Mode screen. The roll offset popup menu appears with three options: **Exit**, **Go**, and **Set**.

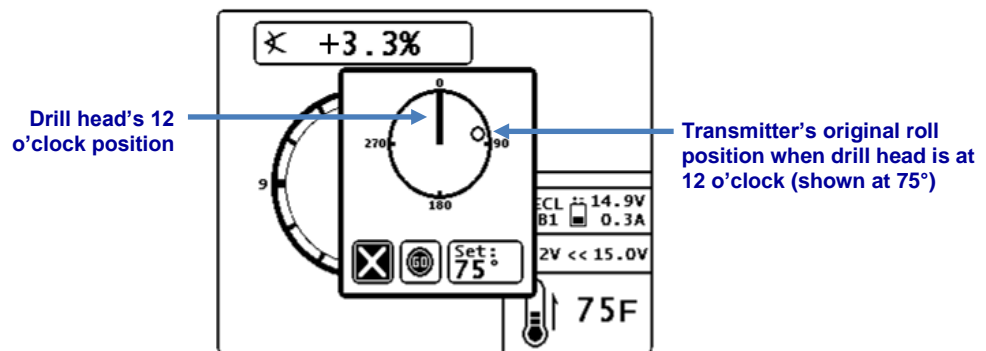

**Roll Offset Menu**

- X (Exit)** Exits the roll offset menu without saving changes
- Go** Activates roll offset with the last set value
- Set** Programs the displayed value as the roll offset

Use the remote display's direction buttons to highlight the desired option and press the Execute button (the curved arrow) to select it. Once the roll offset is programmed, the screen looks like this:

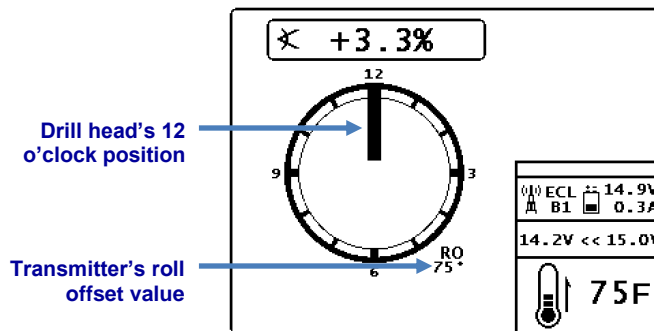

**Cable Mode Screen with Roll Offset**

While roll offset is active, press the right direction button to access the roll offset menu from the cable mode screen. The **Go** option is now replaced by **Stop**. The roll value displayed in the Set option will be that of the transmitter after roll offset is disabled. Select Stop to disable roll offset and return to the cable mode display screen. Select Set to program the roll offset to the displayed value.

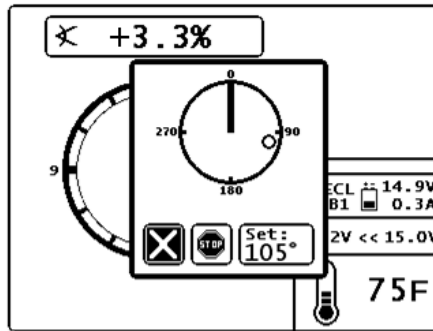

**Roll Offset Menu (Disable or Set)**

- X (Exit)** Exits the roll offset menu without saving changes
- Stop** Disables roll offset
- Set** Sets the displayed value as the roll offset

## Target Steering

When a target depth has been programmed into the receiver and the remote is receiving telemetry data, the Target Steering display screen appears. Your remote display operator's manual provides detailed information on target steering.

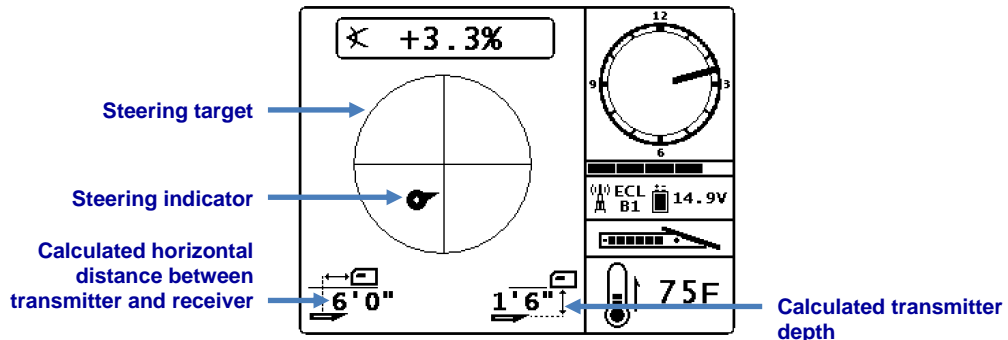





**Target Steering Screen**

## Appendix A: System Specifications

The power requirements and environmental requirements for the DigiTrak Multi-Function Cable Box and remote displays are listed below.

### Power Requirements

Device (Model Number)	Operational Voltage	Operational Current
DigiTrak Multi-Function Cable Box	12–28 V 	6 A max
DigiTrak Remote MFD Display (MFD)	12–28 V 	3.2 W max
DigiTrak Remote F Series Display (FSD)	12–28 V 	3.2 W max
DigiTrak Eclipse and F Series Cable Transmitter (ECP, FC)	9–28 V 	6 A max
DigiTrak Eclipse Steering Tool (SST)	9–28 V 	6 A max

### Environmental Requirements

Device	Relative Humidity	Operating Temperature	System Working Altitude
DigiTrak Multi-Function Cable Box	<90%	-4 to 140° F (-20 to 60° C)	Up to 6561 ft. (2000 m)
DigiTrak MFD Remote Display (MFD)	<90%	-4 to 140° F (-20 to 60° C)	
DigiTrak F Series Remote Display (FSD)	<90%	-4 to 140° F (-20 to 60° C)	
DigiTrak Eclipse and F Series Transmitter (ECP, FC)	<100%	-4 to 180° F (-20 to 82° C)	
DigiTrak Eclipse Steering Tool (SST)	<100%	-4 to 180° F (-20 to 82° C)	

## Appendix B: Transmitter Wire Repair or Replacement

The cable lead and other end cap components in the cable transmitter must be replaced when the wire shows wear, twists, or abrasions. This involves removing the transmitter end cap to access the cable lead connection to the transmitter base. The Replaceable Wire Kit (DCKIT) includes enough parts to replace the cable lead two times. You will also need a standard screw driver.

The DCKIT contains:

- Two cable leads
- Four Torx screws
- Four lock washers
- Four 2-021 O-rings
- Two screw insulators
- Two 2-106 O-rings
- Two brass set screws
- Three white nylon set screws
- One T15 Torx wrench
- One each  $\frac{5}{64}$ ",  $\frac{1}{8}$ ", and  $\frac{3}{32}$ " Allen wrenches
- One tube of Noalox anti-oxidant compound

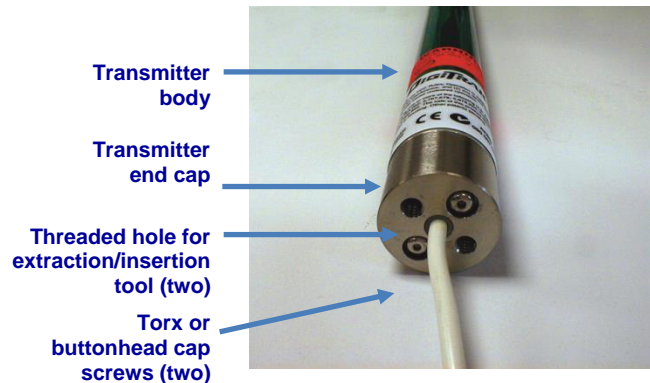

**Wire End of Transmitter**

To disassemble and reassemble the transmitter end cap:

2. Using the  $\frac{5}{64}$ " Allen wrench or the T15 Torx wrench, depending on the screw type installed, remove the two Torx or buttonhead cap screws and lock washers.
3. Pull the end cap from the transmitter base.
4. Identify the deepest set screw depression in the base. Using the  $\frac{1}{8}$ " Allen wrench or a standard screw driver, remove the white nylon set screw. There will be a brass set screw behind the nylon screw that holds the cable in place.



**Note** Do not tamper with the brass set screw and O-ring located on the opposite side of the base in the shallow depression.

6. Using the  $\frac{3}{32}$ " Allen wrench, remove the brass set screw inside the transmitter base that holds the cable lead to the base.
7. Remove the old wire, the 2-106 O-ring, and the screw insulator. Removing the old wire from the base may require some force.
8. Install a new insulator and 2-106 O-ring onto a new cable lead, and insert the wire in the base. Ensure only  $\frac{5}{16}$ " of the wire coating is stripped back from the end of the tinned cable lead.

9. Install a new brass set screw using the  $\frac{3}{32}$ " Allen wrench. Push the cable lead in while tightening the set screw to ensure a good connection.
10. Using the standard screw driver or the  $\frac{1}{8}$ " Allen wrench, install a new white nylon set screw into the side of the transmitter base.

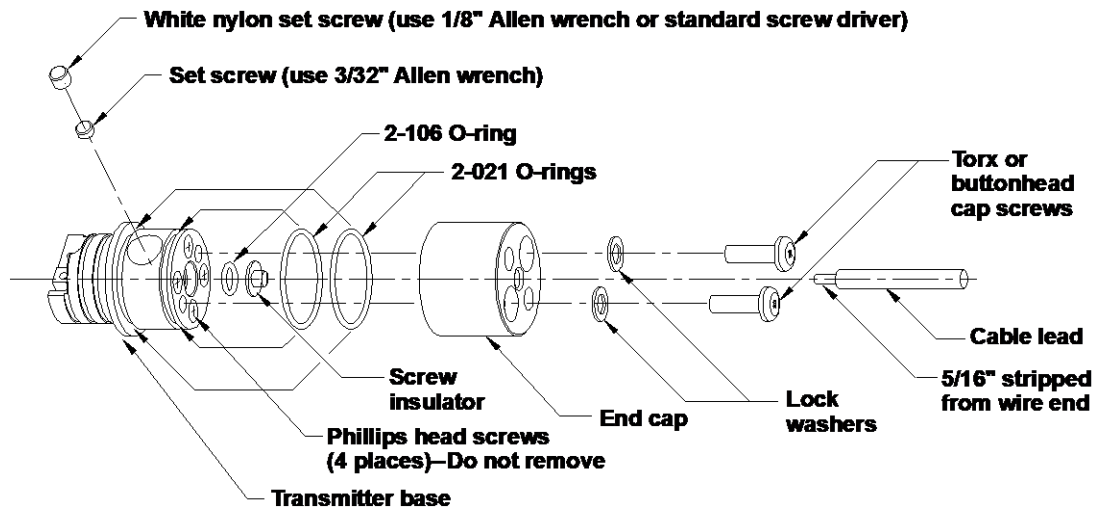

**Exploded View of Cable Transmitter Base and End Cap Assemblies**

11. Install two new 2-021 O-rings.
12. Coat the top and sides of the base with a thin layer of Noalox to prevent electrical corrosion. Do not substitute standard grease.
13. Replace end cap and line up the screw holes on the base with the unthreaded holes on the cap.
14. Install two new lock washers and Torx screws, and tighten the screws in place using the T15 Torx wrench.



**Note** Use care when threading the Torx screws into the base to avoid cross-threading.



## DCI Standard Warranty

DCI warrants that it will either repair or replace any product that fails to operate in conformity to DCI's published specifications at the time of shipment due to a defect in materials or workmanship during the warranty period for that product, subject to the terms set forth below.

Category	Warranty Period
Falcon Transmitters (19" and 15")	Three years from date of purchase or first 500 hours of use, whichever occurs first.
All Other Transmitters	Ninety days from date of purchase
Locators, Remote Displays, Battery Chargers and Rechargeable Batteries	One year from date of purchase
Software*	One year from date of purchase
Other Accessories	Ninety days from date of purchase
Service/Repair	Ninety days from date of repair

\* For software products, in lieu of the warranty set forth above, DCI warrants that it will either update any defective software to bring it into material compliance with DCI's specifications for such software, or refund the purchase price paid for the software.

### Terms

- The 3-yr/500-hr warranty period for a Falcon transmitter is conditioned on registration of the purchase with DCI within 90 days of the date of purchase. If the customer fails to register the purchase during this time frame, the warranty period for the transmitter will instead be ninety days from date of purchase.
- Warranty coverage for a warranty replacement transmitter shall tie back to the original transmitter(s) submitted for warranty coverage. For example, if a Falcon transmitter is owned for one year and used for 250 hours, the warranty coverage for the replacement will be an additional two years or an additional 250 hours of use, whichever comes first.
- "Hours of use" for purposes of the Falcon transmitter warranty means active run-time hours, as measured internally by Falcon transmitters.
- In the event of a valid warranty submission, the choice of remedy (for example, to repair or replace a defective product or, in the case of defective software, to update or refund), shall be at DCI's sole discretion. DCI reserves the right to use remanufactured replacement parts for repairs.
- The above warranties only apply to new products purchased directly from DCI or from a DCI-authorized dealer.
- The ultimate determination of whether a product qualifies for warranty replacement shall be at DCI's sole discretion.

### Exclusions

- Transmitters that have exceeded the maximum temperature, as indicated by the system.
- Defect or damage caused by misuse, abuse, improper installation, improper storage or transport, neglect, accident, fire, flood, use of incorrect fuses, contact with high voltages or injurious substances, use of system components not manufactured or supplied by DCI, failure to follow the operator's manual, use other than that for which the product was intended or other events beyond the control of DCI.
- Any transmitter used with an improper housing, or damage caused to a transmitter from improper installation into or retrieval from a housing.
- Damage during shipment to DCI.

Any modification, opening up, repair or attempted repair of a product, or any tampering or removal of any serial number, label or other identification of the product, will void the warranty.

DCI does not warrant or guarantee the accuracy or completeness of data generated by HDD guidance/locating systems. The accuracy or completeness of such data may be impacted by a variety of factors, including (without limitation) active or passive interference and other environmental conditions, failure to calibrate or use the device properly and other factors. DCI also does not warrant or guarantee, and disclaims liability for, the accuracy and completeness of any data generated by any external source that may be displayed on a DCI device, including (without limitation) data received from a drill rig.

DCI may make changes in design and improvements to products from time to time. DCI shall have no obligation to upgrade any previously manufactured DCI product to include any such changes.

THE FOREGOING IS THE SOLE WARRANTY FOR DCI PRODUCTS (OTHER THAN THE 5-YR/750-HR EXTENDED WARRANTY FOR FALCON 15/19" TRANSMITTERS). DCI DISCLAIMS ALL OTHER WARRANTIES, EXPRESS OR IMPLIED, INCLUDING BUT NOT LIMITED TO IMPLIED WARRANTIES OF MERCHANTABILITY AND FITNESS FOR A PARTICULAR PURPOSE, IMPLIED WARRANTY OF NON-INFRINGEMENT, AND ANY IMPLIED WARRANTY ARISING FROM COURSE OF PERFORMANCE, COURSE OF DEALING, OR USAGE OF TRADE, ALL OF WHICH ARE HEREBY DISCLAIMED.

In no event shall DCI or anyone else involved in the creation, production, sale or delivery of the DCI product ("partners") be liable for any damages arising out of the use or inability to use the DCI product, including but not limited to indirect, special, incidental, or consequential damages, or for any cover, loss of information, profit, revenue or use, based upon any claim for breach of warranty, breach of contract, negligence, strict liability, or any other legal theory, even if DCI has been advised of the possibility of such damages. In no event shall DCI or its partners' liability exceed the purchase price for the product.

This warranty is not assignable or transferable. This warranty is the entire agreement between DCI and purchaser, and may not be expanded or amended in any way other than in writing by DCI.

## Product demonstrations

DCI personnel may be present at a job site to demonstrate basic usage, features, and benefits of DCI products. DCI personnel are present only to demonstrate a DCI product. DCI does NOT provide locating services or other consulting or contracting services. DCI does not assume any duty to train the user or any other person, and does not assume responsibility or liability for the locating or other work performed at a job site at which DCI personnel or equipment are or have been present.

## Translations

This document may be a translation of the original English language version. The purpose of this translation is to assist the product user. However, in the event of any discrepancy in meaning or interpretation between the translation and the original English language version, the original English language version shall control. A copy of the original English language version of this document may be found at [digital-control.com](http://digital-control.com).